

# Installation Instructions

## Ground Fixed

Djembes  
Page 1 of 4



Instrument Components:

Djembes are pre-assembled

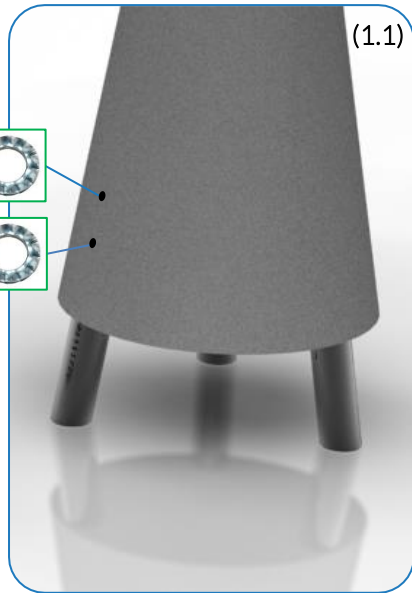

Weight of heaviest part 23kg (Large Djembe)

**1. Assemble Ground Fixing Posts** to base of sambas using **M8x25mm security screws** and **lock washers**. (1.1)(See Assembly Guide)

**2. Arrange Djembe** with minimum spacing between each drum at **500mm** and mark holes for excavation.

**3. Excavate marked holes** to **350mm depth** making sure the holes have a level base allow the Djembes to sit vertical.

**4. Once happy with location** of the Djembes, **fill holes** using rapid hardening **concrete**. Be sure to compact concrete around metal brackets and leave to dry according to manufactures guidelines.

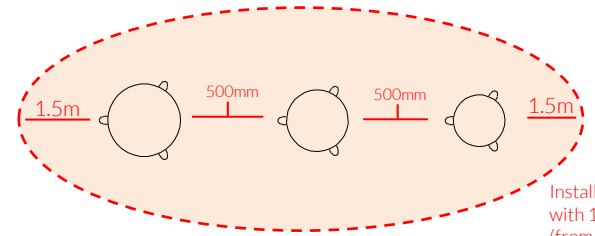

Install Instrument with 1.5m free space (from widest point) around it.

**CAUTION: Drum surface can get hot in direct sunlight, if possible install in shaded areas.**

Djembes will arrive on site in pre set heights. In ground fixing depth 300mm for all 3 Drums.

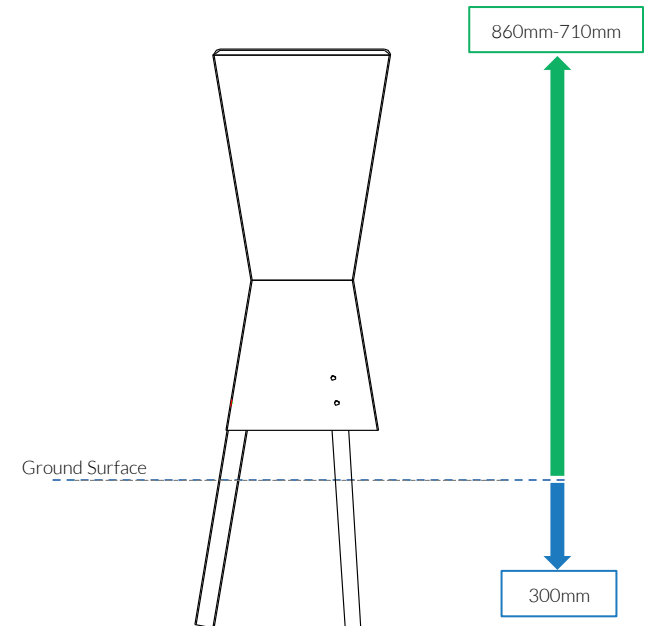

Ground Fix Components:



Spares available from [percussionplay.com](http://percussionplay.com) or from your local distributor

48 Kg

Tools:

 x1  
 TX 40 Driver Bit

## Ground Fixed

Djembes  
Page 2 of 4





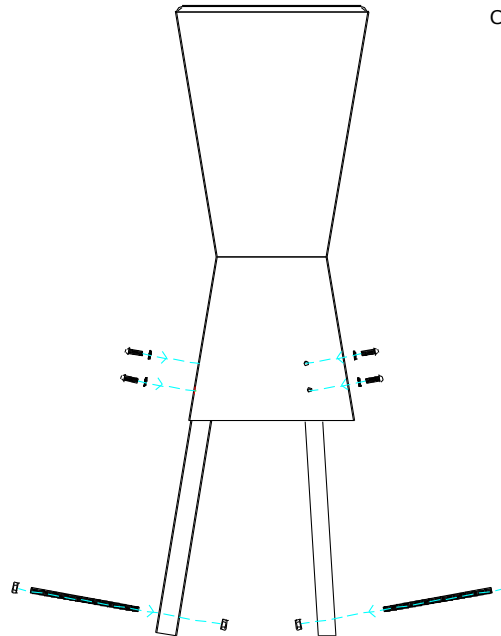
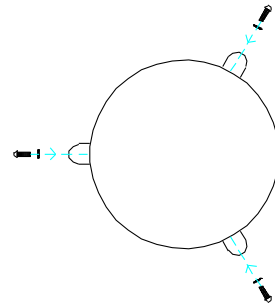

Instrument  
Components:

Djembes  
are pre-  
assembled

Thread Lock Solution  
Required (Not Supplied)



### COMPONENTS LIST:

-  M8x25 Pin torx X18
-  M8 Lock washer X18
-  M10 Nut X18
-  M10x200 Threaded Bar X9



Played with hands

Ground Fix  
Components:

 x18  
 M8x25 Security Screw

 x18  
 M8 Lock Washer

Spares available from  
[percussionplay.com](http://percussionplay.com) or from your  
local distributor

44 Kg

# Ground Fix Installation

Tools:  
 x1  
 TX 40 Driver Bit

Ground Fixed  
 Djembes  
 Page 3 of 4



Components:

 x18  
 M8x25mm Pin Torx

 x18  
 M8 Lock Washer

1

Attach Ground Fix Legs to base of each drum using M8x25 Bolts and lock washers provided.

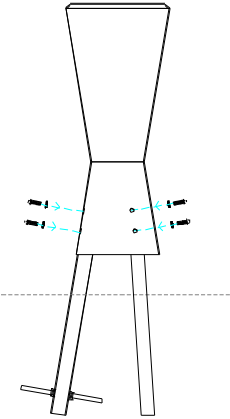
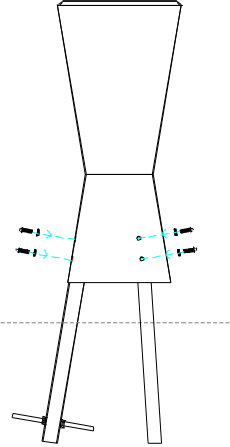
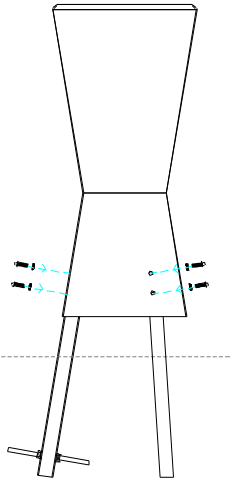

2

Excavate 3 holes 350mm deep. Each hole should taper down making the base diameter at least 100mm larger than the surface hole

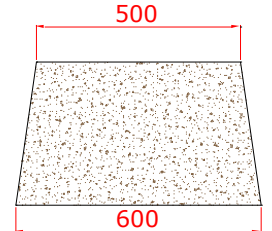
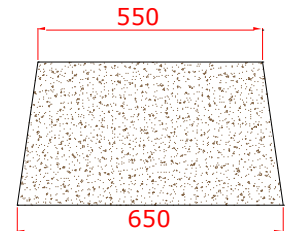
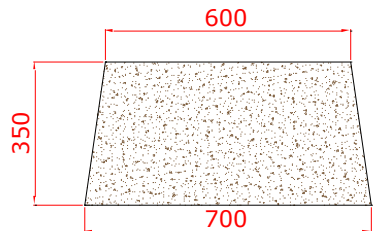
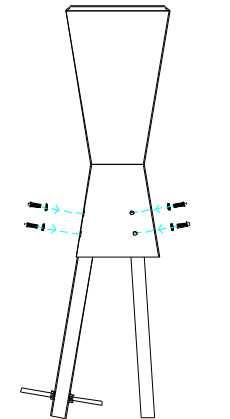
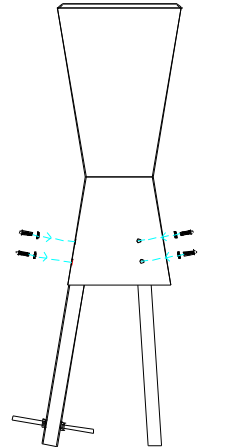
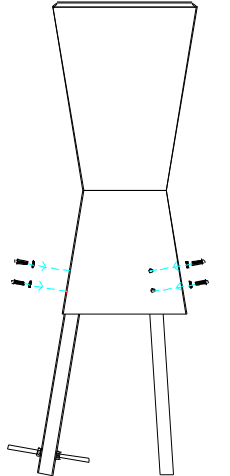

# Ground Fix Installation

Foundations should not present a hazard. These foundations are recommended as a guide, for more information on foundation details for various surface see Part 1 of BS EN 1176.

## Ground Fixed

Djembes  
Page 4 of 4



Components:



Metric Conversion:  
50mm/ 2"  
350mm/ 14"  
500mm/ 19.5"  
550mm/ 21.5"  
600mm/ 24"  
650mm/ 25.5"  
700mm/ 27.5"

3

Compact each hole with a maximum of 50mm of aggregate and lower each samba into its hole

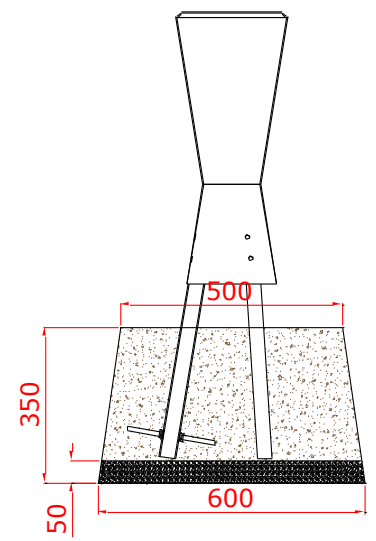
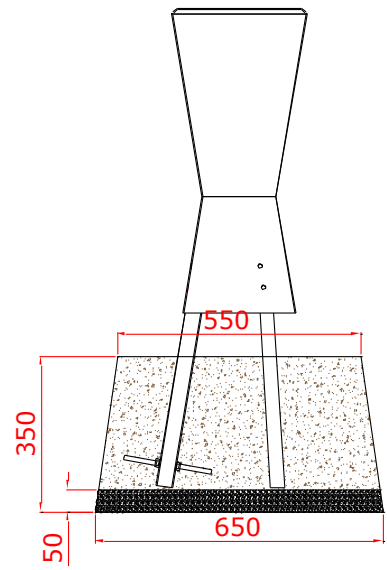
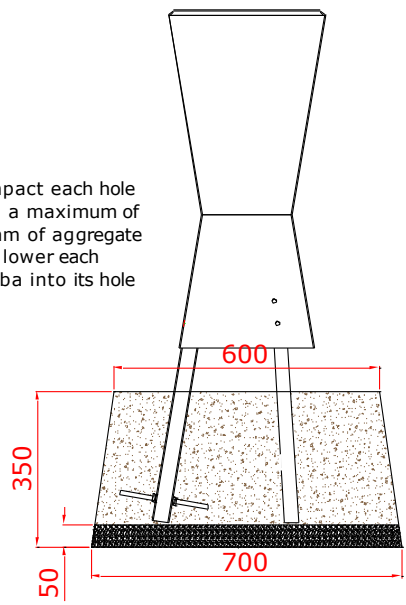

4

Fill each hole with fast drying concrete to manufacturers specifications.

